

PR



9202

Pulse isolator

Nr. 9202V103-DK
Produktversion: 9202-003



SIGNALS THE BEST

- DK ▶** PR electronics A/S tilbyder et bredt program af analoge og digitale signalbehandlingsmoduler til industriel automation. Programmet består af Isolatorer, Displays, Ex-barrierer, Temperaturtransmittere, Universaltransmittere mfl. Vi har modulerne, du kan stole på i selv barske miljøer med elektrisk støj, vibrationer og temperaturudsving, og alle produkter opfylder de strengeste internationale standarder. Vores motto »Signals the Best« er indbegrebet af denne filosofi – og din garanti for kvalitet.
- UK ▶** PR electronics A/S offers a wide range of analogue and digital signal conditioning modules for industrial automation. The product range includes Isolators, Displays, Ex Interfaces, Temperature Transmitters, and Universal Modules. You can trust our products in the most extreme environments with electrical noise, vibrations and temperature fluctuations, and all products comply with the most exacting international standards. »Signals the Best« is the epitome of our philosophy – and your guarantee for quality.
- FR ▶** PR electronics A/S offre une large gamme de produits pour le traitement des signaux analogiques et numériques dans tous les domaines industriels. La gamme de produits s'étend des transmetteurs de température aux afficheurs, des isolateurs aux interfaces SI, jusqu'aux modules universels. Vous pouvez compter sur nos produits même dans les conditions d'utilisation sévères, p.ex. bruit électrique, vibrations et fluctuations de température. Tous nos produits sont conformes aux normes internationales les plus strictes. Notre devise »SIGNALS the BEST« c'est notre ligne de conduite - et pour vous l'assurance de la meilleure qualité.
- DE ▶** PR electronics A/S verfügt über ein breites Produktprogramm an analogen und digitalen Signalverarbeitungsmodulen für die industrielle Automatisierung. Dieses Programm umfasst Displays, Temperaturtransmitter, Ex- und galvanische Signaltrenner, und Universalgeräte. Sie können unsere Geräte auch unter extremen Einsatzbedingungen wie elektrisches Rauschen, Erschütterungen und Temperaturschwingungen vertrauen, und alle Produkte von PR electronics werden in Übereinstimmung mit den strengsten internationalen Normen produziert. »Signals the Best« ist Ihre Garantie für Qualität!

PULSE ISOLATOR

9202

INDHOLD

Advarsel.....	2
Signaturforklaring	2
Sikkerhedsregler.....	2
Afmontering af system 9000	4
EF-Overensstemmelseserklæring	5
Avancerede features.....	6
Anvendelse	6
Teknisk karakteristik	6
Applikationer	7
PR 4501 Display- / programmeringsfront	8
Bestillingsskema 9202B	9
Elektriske specifikationer.....	9
Konfigurering af kabelfejlscheck	11
Funktionsbeskrivelse.....	12
Tilslutninger	13
Blokdiagram	14
Visning af signal- og kabelfejl uden displayfront	15
Programmering / betjening af trykknapper	16
Rullende hjælpetekster i displaylinie 3.....	18
Rutediagram	19
Rutediagram, Avancerede indstillinger (ADV.SET)	20
Appendix	21
IECEX Installation Drawing	22
ATEX Installationstegning	24
FM Installation Drawing.....	26
Safety Manual.....	28



ADVARSEL

Følgende operationer bør kun udføres på modulet i spændingsløs tilstand og under ESD-sikre forhold:

- Installation, ledningsmontage og -demontage.
- Fejlfinding på modulet.

Reparation af modulet og udskiftning af sikringer må kun foretages af PR electronics A/S.



ADVARSEL

Modulets frontplade må ikke åbnes, da dette vil medføre skade på stikforbindelsen til display- / programmeringsfronten PR 4501. Modulet indeholder ingen DIP-switches eller jumpere.

SIGNATURFORKLARING



Trekant med udråbstegn: Læs manualen før installation og idriftsættelse af modulet for at undgå hændelser, der kan føre til skade på personer eller materiel.



CE-mærket er det synlige tegn på modulets overensstemmelse med EU-direktivernes krav.



Dobbelt isolation er symbolet for, at modulet overholder ekstra krav til isolation.



Ex - Modulet er godkendt efter ATEX-direktivet til brug i forbindelse med installationer i eksplosionsfarlige områder.

SIKKERHEDSREGLER

DEFINITIONER:

Farlige spændinger er defineret som områderne: 75...1500 Volt DC og 50...1000 Volt AC.

Teknikere er kvalificerede personer, som er uddannet eller oplært til at kunne udføre installation, betjening eller evt. fejlfinding både teknisk og sikkerhedsmæssigt forsvarligt.

Operatører er personer, som under normal drift med produktet skal indstille og betjene produktets trykknapper eller potentiometre, og som er gjort bekendt med indholdet af denne manual.

MODTAGELSE OG UDPAKNING

Udpak modulet uden at beskadige det. Kontrollér ved modtagelsen, at modultypen svarer til den bestilte. Indpakningen bør følge modulet, indtil dette er monteret på blivende plads.

MILJØFORHOLD

Undgå direkte sollys, kraftigt støv eller varme, mekaniske rystelser og stød, og udsæt ikke modulet for regn eller kraftig fugt. Om nødvendigt skal opvarmning, ud over de opgivne grænser for omgivelsestemperatur, forhindres ved hjælp af ventilation.

Modulet skal installeres i forureningsgrad 2 eller bedre.

Modulet er designet til at være sikkert mindst op til en højde af 2000 m.

INSTALLATION

Modulet må kun tilsluttes af teknikere, som er bekendte med de tekniske udtryk, advarsler og instruktioner i manualen, og som vil følge disse.

Hvis der er tvivl om modulets rette håndtering, skal der rettes henvendelse til den lokale forhandler eller alternativt direkte til:

PR electronics A/S
www.prelectronics.dk

Ved tilslutning af flerkorede ledninger med farlig spænding skal ledningsenderne forsynes med ledningstykker.

Beskrivelse af indgang / udgang og forsyningsforbindelser findes på blokdiagrammet og sideskiltet.

Modulet er forsynet med skrueterminaler og skal forsynes fra en dobbeltisoleret/forstærket isoleret spændingsforsyning. En afbryder placeres let tilgængeligt og tæt ved modulet. Afbryderen skal mærkes således, at der ikke er tvivl om, at den afbryder spændingen til modulet.

Ved installation på Power Rail 9400 bliver forsyningsspændingen leveret af Power Control Unit type 9410.

Produktionsår fremgår af de to første cifre i serienummeret.

KALIBRERING OG JUSTERING

Under kalibrering og justering skal måling og tilslutning af eksterne spændinger udføres i henhold til denne manual, og teknikeren skal benytte sikkerhedsmæssigt korrekte værktøjer og instrumenter.

BETJENING UNDER NORMAL DRIFT

Operatører må kun indstille eller betjene modulerne, når disse er fast installeret på forsvarlig måde i tavler el. lignende, så betjeningen ikke medfører fare for liv eller materiel. Dvs., at der ikke er berøringsfare, og at modulet er placeret, så det er let at betjene.

RENGØRING

Modulet må, i spændingsløs tilstand, rengøres med en klud let fugtet med destilleret vand.

ANSVAR

I det omfang instruktionerne i denne manual ikke er nøje overholdt, vil kunden ikke kunne rette noget krav, som ellers måtte eksistere i henhold til den indgåede salgsaftale, mod PR electronics A/S.

AFMONTERING AF SYSTEM 9000

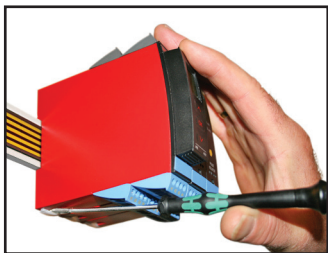

Billede 1:

Modulet frigøres fra power railen ved at løfte i den nederste lås.

EF-OVERENSSTEMMELSESERKLÆRING

Som producent erklærer

PR electronics A/S
Lerbakken 10
DK-8410 Rønde

hermed at følgende produkt:

Type: 9202
Navn: Pulse isolator

er i overensstemmelse med følgende direktiver og standarder:

EMC-direktivet 2004/108/EF og senere tilføjelser

EN 61326-1 : 2006

For specifikation af det acceptable EMC-niveau henvises til modulets elektriske specifikationer.

Lavspændingsdirektivet 2006/95/EF og senere tilføjelser

EN 61010-1 : 2001

ATEX-direktivet 94/9/EF og senere tilføjelser

EN 60079-0:2009, EN 60079-11:2007, EN 60079-15:2005,
EN 60079-26:2007, EN 61241-11:2006
ATEX-certifikat: KEMA 07ATEX0146 X

Bemyndiget organ:

DEKRA Certification B.V. (0344)
Utrechtseweg 310, 6812 AR Arnhem
P.O. Box 5185, 6802 ED Arnhem
The Netherlands

Rønde, 7. februar 2012



Kim Rasmussen
Producentens underskrift

PULSE ISOLATOR

9202

- *Interface for NAMUR-følere og kontakter*
- *Udvidet autodiagnosticering og kabelfejlsdetektering*
- *1 eller 2 kanaler*
- *Kan forsynes separat eller installeres på power rail, PR type 9400*
- *SIL 2-certificeret via Full Assessment*

Avancerede features

- Konfiguration og monitorering via aftagelig displayfront (PR 4501).
- Valg af direkte eller indirekte funktion for hver kanal via PR 4501.
- Avanceret monitorering af intern kommunikation og gemte data.
- Mulighed for redundant forsyning via power rail og/eller separat forsyning.
- SIL 2-funktionaliteten skal aktivt tilvælges via menupunkt.

Anvendelse

- 9202 kan monteres i sikkert område samt i zone 2 / division 2 og modtage signaler fra zone 0, 1, 2, 20, 21, 22 & M1 / Class I/II/III, Div. 1, Gr. A-G.
- Impulsisolator til overførsel af signaler fra NAMUR-følere og mekaniske kontakter placeret i eksplosionsfarligt område til sikkert område.
- Overvågning af fejlsituationer og kabelbrud via det individuelle statusrelæ og/eller kollektivt elektronisk signal via power rail.
- 9202 er konstrueret, udviklet og certificeret til brug i SIL 2-installationer iht. kravene i IEC 61508.

Teknisk karakteristik

- 1 grøn og 2 gule/røde LEDs i front indikerer normal drift og funktionsfejl.
- 2,6 kVAC galvanisk isolation mellem indgange / udgange / forsyning.

APPLIKATIONER

Indgangssignaler:

Kanal 1:

NAMUR

Mekanisk kontakt

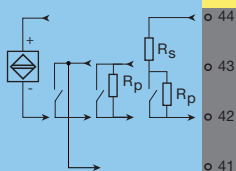

Udgangssignaler:

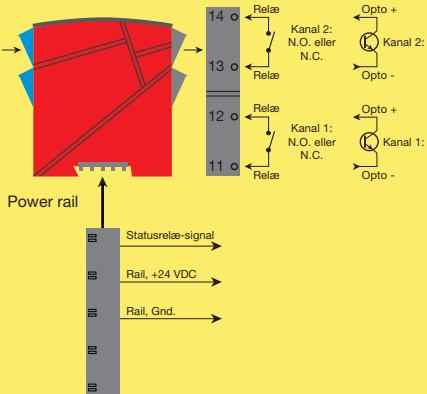

Kanal 2:

NAMUR

Mekanisk kontakt

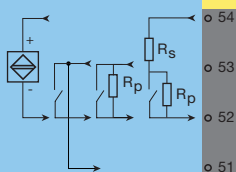

Forsyningsspændinger:

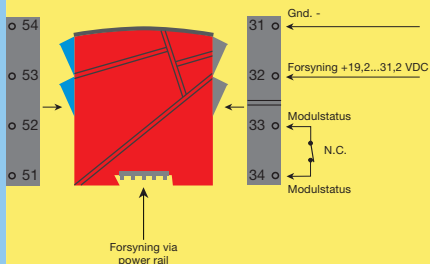

**Zone 0, 1, 2,
20, 21, 22, M1 &
Cl. I/III/III, div. 1
gr. A-G**

Zone 2 / Cl. 1, div. 2, gr. A-D eller sikkert område

PR 4501 DISPLAY- / PROGRAMMERINGSFRONT



Funktionalitet

Den enkle menustruktur og de forklarende hjælpetekster leder dig automatisk gennem opsætningen og gør produktet meget enkelt at anvende. Se beskrivelse af funktioner og opsætningsmuligheder under afsnittet "Programmering / betjening af trykknapper".

Anvendelse

- Kommunikationsinterface til ændring af driftsparametre i 9202.
- Som fastmonteret display til visualisering af procesdata og status.

Teknisk karakteristisk

- Fire liniers LCD-display, linie 1 (5,57 mm høj) viser hver kanals status (OK eller fejl). Linie 2 (3,33 mm høj) viser kanal 1's udgang (ON / OFF), linie 3 (3,33 mm høj) viser kanal 2's udgang (ON / OFF) og linie 4 viser, om modulet er SIL-låst. Statisk prik = SIL-låst og blinkende prik = ikke SIL-låst. Linie 4 viser også status for relæ 1 og relæ 2.
- For at undgå uautoriseret brug kan konfigurationen beskyttes med et password.

Montage / installation

- Klikkes på fronten af 9202.

Bestillingsskema 9202B

Type	Kontakt	Kanaler
9202B	Opto : 1 Relæ N.O. . . . : 2 Relæ N.C. . . . : 3	Enkelt . . . : A Dobbelt. . . : B

4501 = Display- / programmeringsfront

9400 = Power rail

Elektriske specifikationer

Specifikationsområde..... -20...+60°C

Lagringstemperatur -20...+85°C

Fælles specifikationer:

Forsyningsspænding 19,2...31,2 VDC

Max. forbrug ≤ 3 W (2 kanaler)

Sikring 400 mA T / 250 VAC

Isolationsspændinger, test / drift

 Indgange / udgange / forsyning..... 2,6 kVAC / 300 VAC forstærket

 Udgang 1 til udgang 2 1,5 kVAC / 150 VAC forstærket

 Statusrelæ til forsyning 1,5 kVAC / 150 VAC forstærket

Kommunikationsinterface..... Programmeringsfront 4501

Reaktionstid for kabelfejll..... < 200 ms

Kalibreringstemperatur 20...28°C

Hjælpespændinger:

NAMUR-forsyning 8 VDC / 8 mA

Vibration, IEC 60068-2-6..... Test Fc, 1 g, 2...100 Hz

Vibration vedvarende, IEC 60068-2-64..... Test Fh, 1 g, 3...100 Hz

Ledningskvadrat (min. / max.)..... 0,13...2,08 mm² / AWG 26...14
flerkoret ledning

Klemskruetilspændingsmoment..... 0,5 Nm

Relativ luftfugtighed < 95% RH (ikke kond.)

Mål, uden displayfront (HxBxD) 109 x 23,5 x 104 mm

Mål, med displayfront (HxBxD) 109 x 23,5 x 116 mm

Kapslingsklasse..... IP20

Vægt 170 g / 185 g med 4501

Indgange:

Følertyper:

NAMUR i henhold til	EN 60947-5-6
Mekanisk kontakt med serie- (R_s) og parallelmodstand R_p):	
R_s	Nom. 750 Ω
R_p	Nom. 15 $k\Omega$
Frekvensområde.....	0...5 kHz
Min. impulslængde.....	> 0,1 ms
Indgangsmodstand	Nom. 1 $k\Omega$
Trig-niveau, signal	< 1,2 mA, > 2,1 mA
Trig-niveau, kabelfejl.....	< 0,1 mA, > 6,5 mA

Udgange:

Relæudgange:

Statusrelæ:

Max. spænding	125 VAC / 110 VDC
Max. strøm	0,5 A AC / 0,3 A DC
Max. effekt	62,5 VA / 32W

Relæudgange:

Max. frekvens.....	20 Hz
Max. spænding	250 VAC / 30 VDC
Max. strøm	2 A AC / 2A DC
Max. effekt	500 VA / 60 W

Opto, NPN-udgange:

Max. frekvens.....	5 kHz
Min. impulslængde.....	> 0,1 ms
Max. belastning, strøm / spænding.....	80 mA / 30 VDC
Spændingsdrop ved 80 mA.....	< 2,5 VDC

Godkendelser:

EMC 2004/108/EF	EN 61326-1
LVD 2006/95/EF	EN 61010-1
UL, Standard for Safety	UL 61010-1
GOST R	

Marine:

Det Norske Veritas, Ships & Offshore	Stand. f. Certific. No. 2.4
--------------------------------------------	-----------------------------

I.S. / Ex:

ATEX 94/9/EF	KEMA 07ATEX0146 X
IECEX.....	IECEX KEM 06.0039 X
c FM us	3034430-C
GOST Ex	

Funktionel sikkerhed:

SIL2 Certified & Fully Assessed iht. IEC 61508

Konfigurering af kabelfejlscheck

Diagnosticering

Kabelfejlscheck, detekteret og vist uafhængigt for hver kanal:		
Modul:	Konfiguration, fælles for begge kanaler	Kabelfejlsdetektering:
9202	CA.BR = Yes eller CA.SH = Yes	ON
	Ellers:	OFF

Kabelfejlsdetektering

Kabelfejlsdetektering (CA.BR, CA.SH):			
Indgang	Hændelse	Visning	Grænse
Alle	Kabelbrud	CA.BR	< 0,1 mA
Alle	Kortsluttet kabel	CA.SH	> 6,5 mA

Hardware- / softwarefejl

Visning ved hardwarefejl		
Fejlsøgning	Visning	Årsag
Test af kommunikation mellem 4501 / 9202	NO.CO	Fejl i stikforbindelse
EEProm-fejl - check konfiguration	FL.ER	Konfigurationsfejl eller crc-mismatch, recovery-konfiguration er indlæst
Hardwarefejl	DE.ER	Ugyldig recovery-konfiguration i modulet
Hardwarefejl	FC.ER	Ugyldig kode-checksum i 4501
EEProm-fejl - check konfiguration	CO.ER	Ugyldig konfiguration (CRC eller data)
Hardwarefejl	CA.ER	Fejl i fabrikskalibrering
Hardwarefejl	HW.ER	HW-setup - konfigurations-mismatch
Hardwarefejl	OC.ER	Kommunikationsfejl i primær processorkontrol
Hardwarefejl	MS.ER	Primær intern forsyning uden for grænser
Hardwarefejl	MI.ER	Fejl i primær initialiserings-selvtest
Hardwarefejl	MC.ER	Fejl i primær flash eller ram selvtest

! Alle fejlvisninger i display blinker 1 gang pr. sekund samt suppleres med tilhørende hjælpetekst. Hvis fejlen er en kabelfejl, blinker displayets baggrundsbelysning også. Dette kan resettes ved tryk på  tasten.

Fejl, som har indflydelse på begge kanaler, vises som kanal 1 fejl - og kanal 2's linie er blank.

Hardwarefejl kan resettes på to måder. Man kan steppe gennem menuerne, f.eks. hvis den anden kanal skal køre videre, eller slukke og tænde for modulet.

FUNKTIONSBESKRIVELSE

Forbindelseseksempler på tilslutningstegning og blokdiagram (1)...(4)

- (1) NAMUR-føler med kabelfejlsdetektering for brud og kortslutning.
- (2) Mekanisk kontakt med kabelfejlsdetektering for brud og kortslutning, når Rs og Rp er monteret på kontakten.
- (3) Mekanisk kontakt med kabelfejlsdetektering for brud, når Rp er monteret på kontakten.
- (4) Mekanisk kontakt uden kabelfejlsdetektering.

TILSLUTNINGER

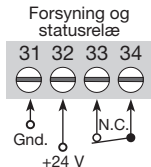
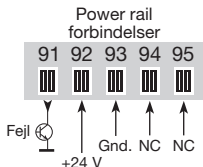

NC = ingen forbindelse

Indgange:

(1)...(4) = Se funktionsbeskrivelse på side 12

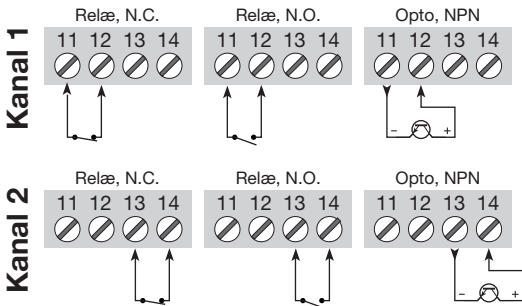
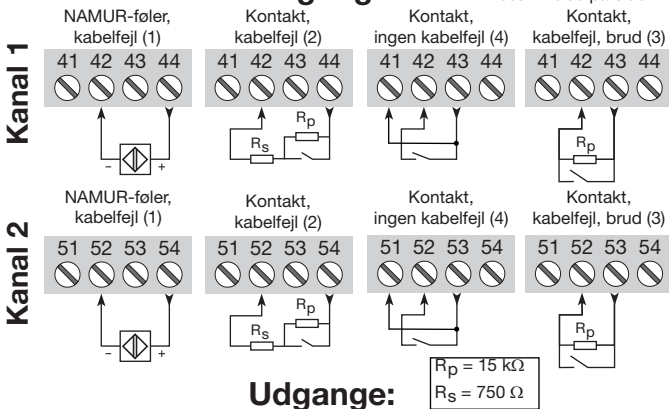

BLOKDIAGRAM

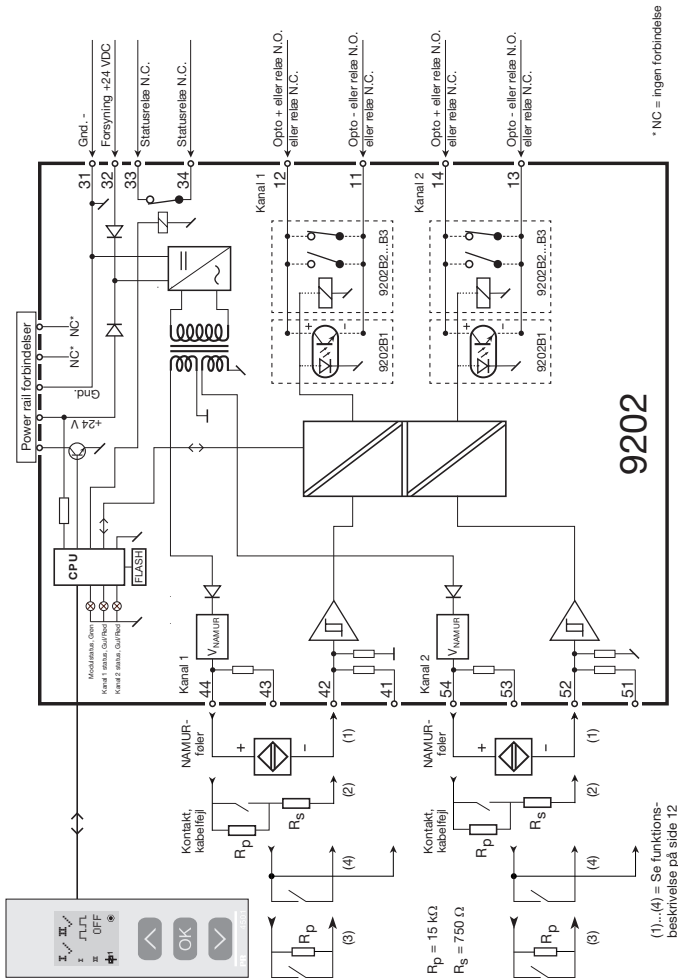

* NC = ingen forbindelse

9202

(1)...(4) = Se funktions-
beskrivelse på side 12

Visning af signal- og kabelfejl uden displayfront

Liste over LED- og fejlsignalvisninger					
Tilstand	Grøn LED	Kanal 1: Gul / rød	Kanal 2: Gul / rød	Statusrelæ, N.C.	Power rail signalstatus
Modul OK	Blinker			Trukket	OFF
Ingen forsyning	OFF	OFF	OFF	Sluppet	ON
Modul defekt	OFF	Rød	Rød	Sluppet	ON
Kanal 1, relæ trukket	Blinker	Gul		Trukket	OFF
Kanal 1, relæ sluppet ved kabelfejl	Blinker	Blinkende rød		Sluppet	ON (hvis aktiveret)
Kanal 1, relæ sluppet	Blinker	OFF		Trukket	OFF
Kanal 2, relæ trukket	Blinker		Gul	Trukket	OFF
Kanal 2, relæ sluppet ved kabelfejl	Blinker		Blinkende rød	Sluppet	ON (hvis aktiveret)
Kanal 2, relæ sluppet	Blinker		OFF	Trukket	OFF

PROGRAMMERING / BETJENING AF TRYKKNAPPER

Dokumentation til rutediagram

Generelt:

Når du skal konfigurere 9202, bliver du guidet igennem samtlige parametre og kan vælge netop de indstillinger, der passer til applikationen. Til hver menu findes en rullende hjælpetekst, som vises i displaylinje 3.

Konfigurationen udføres ved hjælp af de 3 taster:

- ⬆ forøger talværdien eller vælger næste parameter
- ⬇ formindsker talværdien eller vælger forrige parameter
- Ⓞ accepterer valget og går til næste menu

Når konfigurationen er gennemført, returneres til normaltilstand 1.0.

Tryk og hold Ⓞ tasten nede for at gå til forrige menu eller normaltilstand (1.0) uden at gemme de ændrede tal eller parametre.

Hvis ingen taster har været aktiveret i 1 minut, returnerer displayet til normaltilstand (1.0) uden at gemme de ændrede tal eller parametre.

Uddybende forklaringer:

Passwordbeskyttelse: Programmeringsadgang kan forhindres ved indkodning af et password. Passwordet gemmes i impulsisolatoren, så sikkerheden mod uønskede ændringer er så høj som muligt. Default password 2008 giver adgang til alle programmeringsmenyer.

Kabelfejlsinformation via displayfront 4501

Kabelfejl (se grænser i skema) vises i display med CA.BR (Kabelbrud) eller CA.SH (Kabel kortsluttet). Kabelfejl vises individuelt for hver kanal, men konfigureres fælles for begge kanaler. Ved kabelfejl blinker displayets baggrundsbelysning. Dette kan resettes ved tryk på Ⓞ tasten. Når kabelfejlen er udbedret, vender modulet tilbage til normal drift.

Avancerede funktioner

Enheden giver adgang til en række avancerede funktioner, der nås ved at svare "yes" til punktet "adv.set".

Display setup: Her kan man justere kontrast og baggrundsbelysning.

Opsætning af TAG-nummer med 5 alfanumeriske karakterer. Valg af funktionsvisning i linie 2 og 3 på displayet; der vælges mellem visning af digital udgang eller visning af TAG-nummer. Vælges "ALT" skifter displayet mellem digital udgang og TAG-nummer.

Password: Her kan vælges et password mellem 0000 og 9999 til beskyttelse mod uautoriserede ændringer. Enheden leveres default uden password.

Sprog: Der kan i menuen "LANG" vælges mellem 7 forskellige sprogvarianter af hjælpetekster, der fremkommer i menuen. Der kan vælges mellem UK, DE, FR, IT, ES, SE og DK.

Power rail: I menuen "RAIL" vælges om fejl på modulet skal overføres til en central overvågning i PR 9410 power control unit.

Safety Integrity Level: Se Safety Manual for yderligere information.



RULLENDE HJÆLPETEKSTER I DISPLAYLINIE 3

- [01] Angiv korrekt password [PASS]
- [02] Gå til avanceret opsætningsmenu? [ADV.SET]
- [03] Aktiver fejldelektering for kortslettet kabel? [CA.SH]
- [04] Vælg fejldelektering for afbrudt kabel? [CA.BR]
- [05] Aktiver overførsel af statussignal til power rail [RAIL.ER]
- [06] Gå til sprogvalg [SETUP]
- [6/1] Gå til password-indstilling [SETUP]
- [6/2] Gå til display opsætningsmenu [SETUP]
- [6/3] Gå til RAIL opsætningsmenu [SETUP]
- [6/4] Gå til SIL opsætningsmenu [SETUP]
- [07] Vælg Direkte signalbehandling [CH1.FUN] [CH2.FUN]
Vælg Inverteret signalbehandling [CH1.FUN] [CH2.FUN]
- [09] Juster LCD-kontrast [CONTRA]
- [10] Juster LCD-baggrundsbelysning [LIGHT]
- [11] Angiv TAG-nr. på 5 karakterer ["TAGON] ["TAGON]
- [12] Udgangsbelastning vises i display [DISP]
Udgangstatus vises i display
TAG-nr. vises i display
Vekslede information i display
- [13] Konfigurationens SIL-status (åben / låst) [CONFIG]
- [14] Aktiver SIL-lås af konfiguration? [EN.SIL]
- [15] Aktiver password-beskyttelse? [EN.PASS]
- [16] Angiv Nyt password [NEW.PAS]
- [17] Vælg sprog [LANGUA]
- [18] Kortslettet kabel [^ICA.SH] [^{II}OFF]
- [19] Afbrudt kabel [^ION] [^{II}CA.BR]

RUTEDIAGRAM

Hvis ingen taster har været aktiveret i 1 minut, returnerer displayet til normaltstanden 1.0 uden at gemme eventuelle konfigurationsændringer.

- ⏪ Forøgelse af værdi / vælg næste parameter
- ⏩ Formindskelse af værdi / vælg forrige parameter
- OK Acceptor valget og gå til næste menu

Holde OK går til forrige menu / returnerer til 1.0 uden at gemme

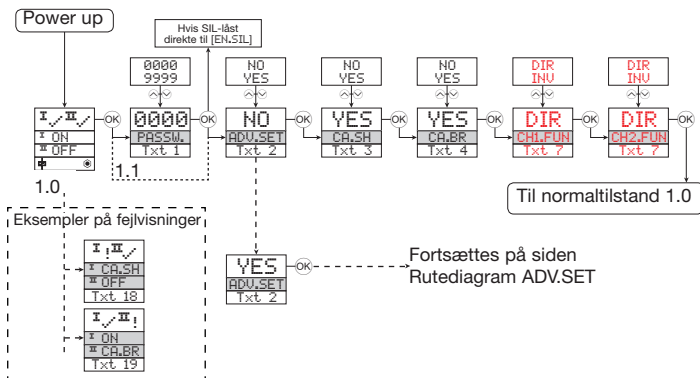

1.0 = Normaltilstand.

Linie 1 viser status for kanal 1 og kanal 2.

Linie 2 viser status for sensor 1.

Linie 3 viser status for sensor 2.

Linie 4 indikerer om modulet er SIL-låst.

1.1 = Kun hvis beskyttet med password.

1.2 = Hvis password er valgt

Linie 1 symboler:

⏪ / ⏩ = OK. Blinkende ❗ = fejl.

Linie 2 og 3 symboler:

Indgangsfrekvens > 1 Hz = ⏪ ⏩ ⏪ ⏩

Linie 4 symboler:

Statisk prik = SIL-låst.

Blinkende prik = ikke SIL-låst.

Rød tekst viser safety parametre i en SIL-konfiguration. Se Safety Manual for yderligere information.

RUTEDIAGRAM, AVANCEREDE INDSTILLINGER (ADV.SET)

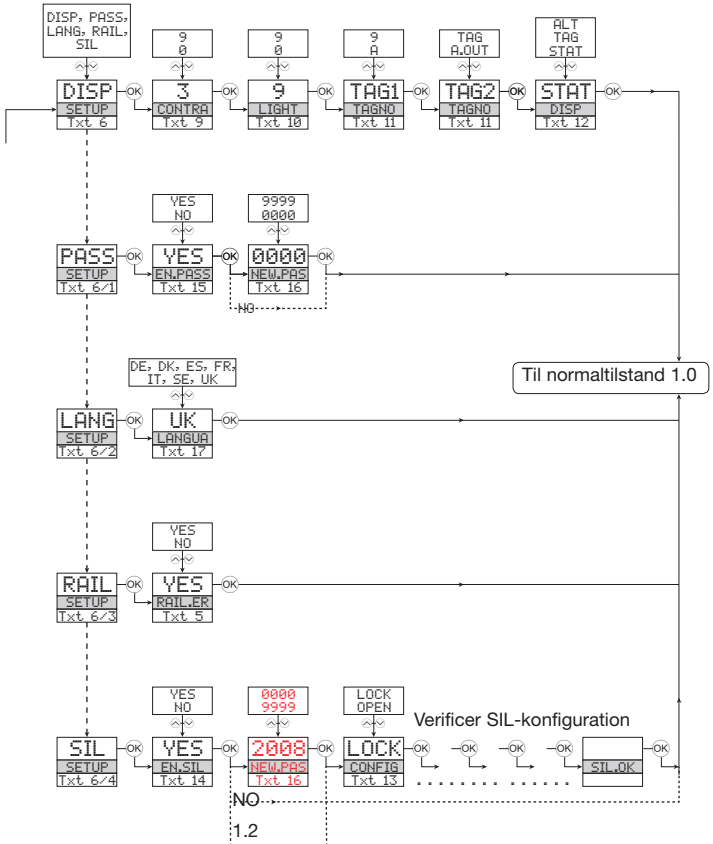

APPENDIX

IECE_x INSTALLATION DRAWING

ATEX INSTALLATION DRAWING

FM INSTALLATION DRAWING

SAFETY MANUAL

IECEx Installation drawing



For safe installation of 9202B the following must be observed. The module shall only be installed by qualified personnel who are familiar with the national and international laws, directives and standards that apply to this area.

Year of manufacture can be taken from the first two digits in the serial number.



For Installation in Zone 2 / Division 2 the following must be observed.

The 4501 programming module is to be used solely with PR electronics modules. It is important that the module is undamaged and has not been altered or modified in any way. Only 4501 modules free of dust and moisture shall be installed.

IECEx Certificate	KEM 06.0039 X
Marking	[Ex ia Ga] IIC/IIB/IIA Ex nA nC IIC T4 Gc [Ex ia Da] IIIC [Ex ia Ma] I
Standards	IEC60079-15 :2005, IEC60079-11:2011, IEC60079-0: 2011 IEC60079-26: 2006

Supply terminal (31,32)

Voltage: 19.2 – 31.2 VDC

Status Relay. terminal (33,34)

		Zone 2 Installation
Voltage max:	125VAC / 110VDC	32VAC / 32VDC
Power max:	62,5VA / 32W	16VA / 32W
Current max:	0.5A AC / 0.3ADC	0.5A AC / 1ADC

Installation notes.

Install in pollution degree 2, overvoltage category II as defined in IEC60664-1

Do not separate connectors when energized and an explosive gas mixture is present.

Do not mount or remove modules from the Power Rail when an explosive gas mixture is present.

Disconnect power before servicing.

The wiring of unused terminals is not allowed.

In type of protection [Ex ia Da] the parameters for intrinsic safety for gas group IIB are applicable.

For installation in Zone 2, the module shall be installed in an enclosure in type of protection Ex n or Ex e, providing a degree of protection of at least IP54. Cable entry devices and blanking elements shall fulfill the same requirements.

For installation on Power Rail in Zone 2, only Power Rail type 9400 supplied by Power Control Unit type 9410 (Type Examination Certificate KEMA 07ATEX0152 X) is allowed.

LERBAKKEN 10, 8410 RØNDE DENMARK

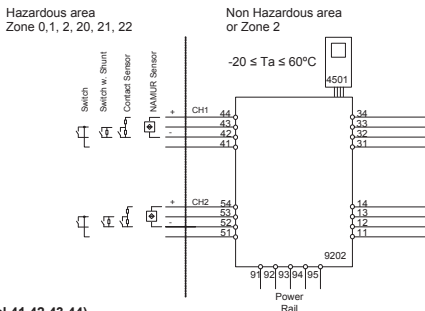
Ex input:
CH1 (terminal 41,42,43,44)
CH2 (terminal 51,52,53,54)
 U_0 : 10.6 VDC

 I_0 : 12 mA DC

 P_0 : 32 mW

 L_0/R_0 : 1150 μ H/ Ω
 U_m : 253 V max. 400 Hz

Supply / Output:
(terminal 11,12,13,14)
(terminal 31,32,33,34)
(terminal 91,92,93,94,95)

	IIC	IIB	IIA	I
C_0	2.0 μ F	6.0 μ F	18 μ F	90 μ F
L_0	260 mH	780 mH	1000 mH	1000 mH

Terminal CH1(11,12) CH2(13,14)
Digital output:

 Voltage max.
Current max.

NPN output:

 30 VDC
80 mA

Terminal CH1(11,12) CH2(13,14)
Relay output:

 Voltage max.
Power max.
Current max.

Non Hazardous location

 250 VAC / 30 VDC
500 VA / 60 W
2 AAC / 2 ADC

Zone 2 installation

 32 V AC / 30 VDC
64 VA / 60 W
2 AAC / 2 ADC

ATEX Installationstegning



For sikker installation af 9202B skal følgende overholdes: Modulet må kun installeres af kvalificerede personer, som er bekendt med national og international lovgivning, direktiver og standarder i det land, hvor modulet skal installeres.
Produktionsår fremgår af de to første cifre i serienummeret



For installation i zone 2 / division 2 skal følgende overholdes:
Den aftagelige displayfront til programmering 4501 er udelukkende beregnet til brug på PR electronics moduler. Det er vigtigt, at displayet er ubeskadiget, ikke ombygget eller på anden måde forandret. 4501 må kun anvendes, hvis det er fri for støv og/eller fugt.

ATEX-certifikat KEMA 07 ATEX 0146 X

Mærkning



II (1) G [Ex ia Ga] IIC/IIB/IIA
II 3G Ex nA nC IIC T4 Gc
I (1) D [Ex ia Da] IIIC
I (M1) [Ex ia Ma] I

Standarder

EN 60079-0 : 2009, EN 60079-11 : 2007, EN 60079-15 : 2005
EN 60079-26 : 2007, EN 61241-11 : 2006

Forsyningsklemme (31,32)

Spænding: 19,2 – 31,2 VDC

Statusrelæ, klemme (33,34)

Max. spænding:	125 VAC / 110 VDC	Zone 2-installation
Max. forbrug:	62,5 VA / 32 W	32 VAC / 32 VDC
Max. strøm:	0,5 A AC / 0,3 ADC	16 VA / 32 W
		0,5 A AC / 1 ADC

Installationsforskrifter:

Installer i forureningsgrad 2, overspændingskategori II som defineret i EN 60664-1.

Monter/demonter ikke stik, når forsyning er tilsluttet og der forefindes en eksplosionsfarlig gasblanding.

Monter/demonter ikke modulet på Power Rail, når der forefindes en eksplosionsfarlig gasblanding.
Afbryd forsyning før udførelse af vedligehold og reparation.
Fortrængning i ubenyttede terminaler er ikke tilladt.

Ved beskyttelsesmetode [Ex ia Da] er parametrene for egensikkerhed for gasgruppe IIB gældende.

For installation i zone 2 skal modulet installeres i et hus, som har beskyttelsestype Ex n eller Ex e, og som giver en IP-beskyttelse på mindst IP54. Kabelforskrutninger og blindstik skal opfylde samme krav.

Ved installation på Power Rail type 9400 i zone 2 er det kun tilladt at forsyne Power Rail ved brug af 9410 Power Control Unit (Type Examination Certificate KEMA 07ATEX0152 X).

LERBAKKEN 10, 8410 RØNDE DENMARK

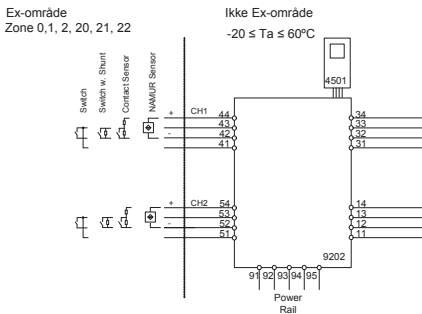

U_o : 10,6 VDC
 I_o : 12 mA DC
 P_o : 32 mW
 L_o/R_o : 1150 μ H/ Ω

U_m : 253 V max. 400 Hz

Forsyning / Udgang:
 (klemme 11,12,13,14)
 (klemme 31,32,33,34)
 (klemme 91,92,93,94,95)

	IIC	IIB	IIA	I
C_o	2,0 μ F	6,0 μ F	18 μ F	90 μ F
L_o	260 mH	780 mH	000 mH	1000 mH

Ex-indgang:
Kanal 1 (klemme 41,42,43,44)
Kanal 2 (klemme 51,52,53,54)
Klemme, Kanal 1(11,12), kanal 2(13,14)
Digital udgang:

Max. spænding

Max. strøm

NPN-udgang:

30 VDC

80 mA

Klemme, kanal 1(11,12), kanal 2(13,14)
Relæudgang:

Max. spænding

Max. forbrug

Max. strøm

Ikke eksplosionsfarligt område

250 VAC / 30 VDC

500 VA / 60 W

2 AAC / 2 ADC

Zone 2-installation

32 VAC / 30 VDC

64 VA / 60 W

2 AAC / 2 ADC

FM Installation drawing



For safe installation of 9202B the following must be observed. The module shall only be installed by qualified personnel who are familiar with the national and international laws, directives and standards that apply to this area.



For Installation in Zone 2 / Division 2 the following must be observed. The 4501 programming module is to be used solely with PR electronics modules. It is important that the module is undamaged and has not been altered or modified in any way. Only 4501 modules free of dust and moisture shall be installed.

c-FM-us Certificate 3034430

Hazardous area

Class I/II/III, Division 1, Group A,B,C,D,E,F,G or Class I, Zone 0/1 Group IIC, [AEx ia] IIC or or Class I, Zone 0/1 Group IIC, [Ex ia] IIC

Simple Apparatus or Intrinsically safe apparatus with entity parameters:
 $V_{max}(U_i) \geq V_t(U_o)$
 $I_{max}(I_i) \geq I_t(I_o)$
 $P_i \geq P_t(P_o)$
 $C_a(C_o) \geq C_{cable} + C_i$
 $L_a(L_o) \geq L_{cable} + L_i$

$U_o / V_t:$ 10.6 V
 $I_o / I_{sc}:$ 12 mA
 $P_o / P_t:$ 32 mW
 $L_o / R_o \text{ La/Ra:}$ 1150 $\mu\text{H}/\Omega$

Group	IIC	IIB	IIA
Group	A,B	C,E,F	D,G
C_o/C_a	2.0 μF	6.0 μF	18 μF
L_o/L_a	260 mH	780 mH	1000 mH

Terminal CH1(44,42) CH2(54,52)

Non Hazardous area or

Class I, Division 2, Group A,B,C,D T4 or Class I, Zone 2 Group IIC T4

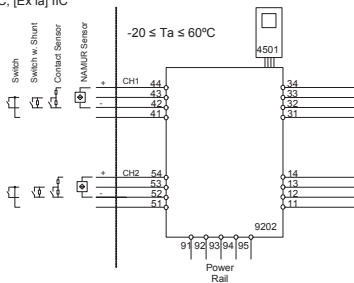

$U_m:$ 253 V max. 400 Hz

Supply / Output
 (terminal 11,12,13,14)
 (terminal 31,32,33,34)
 (terminal 91,92,93,94,95)

LERBAKKEN 10, 8410 RØNDE DENMARK

Terminal (31,32)
Supply:

Voltage	19.2 – 31.2 VDC
Power	max. 3 W

Terminal (33,34)
Status Relay:

Voltage max.	Non Hazardous location: 125 VAC / 110 VDC	Division 2 or Zone 2 installation: 32 VAC / 32VDC
Power max.	62.5 VA / 32 W	16 VA / 32 W
Current max.	0.5 AAC / 0.3 ADC	0.5 AAC / 1 ADC

Terminal CH1(11,12) CH2(13,14)
Digital output:
NPN output:

Voltage max.	30 VDC
Current max.	80 mA

Terminal CH1(11,12) CH2(13,14)
Relay output:
Non Hazardous location:
Division 2 or Zone 2 installation:

Voltage max.	250 VAC / 30VDC	32 VAC / 30VDC
Power max.	500 VA / 60W	64 VA / 60 W
Current max.	2 AAC / 2ADC	2 AAC / 2 ADC

Installation notes:

The installation and wiring shall be in accordance with the Canadian Electrical Code for Canada and National Electrical Code NFPA 70, Article 500 or 505 for installation in USA.

The module must be supplied from a Power Supply having double or reinforced insulation.

The use of stranded wires is not permitted for mains wiring except when wires are fitted with cable ends.

For installation on the 9400 Power Rail the power must be supplied from Power Control Module Unit 9410.

Install in pollution degree 2, overvoltage category II.

The module must be installed in an enclosure suitable for the environment for which it is used.

For installation in Zone 2 or Division 2, the module must be installed in a suitable outer enclosure according to the regulations in the CEC for Canada or NEC for USA.

The module is galvanically isolated and does not require grounding.

Use 60 / 75 °C copper conductors with wire size AWG: (26-14).

Warning: Substitution of components may impair intrinsic safety and / or suitability for Div. 2 / Zone 2.

Warning: To prevent ignition of explosive atmospheres, disconnect power before servicing and do not separate connectors when energized and an explosive gas mixture is present.

Warning: Do not mount or remove modules from the Power Rail when an explosive gas mixture is present.

SAFETY MANUAL

PULSE ISOLATOR

9202

This safety manual is valid for the following product versions:

9202-002

9202-003

0. CONTENTS

1. Observed standards	2
2. Acronyms and abbreviations	2
3. Purpose of the product	3
4. Assumptions and restrictions for use of the product.....	3
4.1 Basic safety specifications	3
4.2 Associated equipment.....	3
4.2.1 Relay output.....	3
4.2.2 Opto output.....	3
4.2.3 Field device.....	3
4.3 Failure rates	3
4.4 Safe parameterisation.....	4
4.5 Installation in hazardous areas	4
5. Functional specification of the safety functions.....	4
6. Functional specification of the non-safety functions	4
7. Safety parameters	4
8. Hardware and software configuration.....	5
9. Failure category.....	5
10. Periodic proof test procedure	5
11. Procedures to repair or replace the product.....	5
12. Maintenance.....	5
13. Documentation for routing diagram	6
13.1 In general	6
13.2 Further explanations.....	6
13.2.1 Password protection	6
13.2.2 Cable fault information via display front 4501	6
13.4 Advanced functions.....	6
13.4.1 Display setup	7
13.4.2 Password	7
13.4.3 Language	7
13.4.4 Power rail	7
13.4.5 Safety integrity level.....	7
14 Safe parameterisation - user responsibility.....	8
14.1 Safety-related configuration parameters.....	8
14.2 Verification procedure.....	8
14.2.1 If no password is set.....	8
14.2.2 If password is set.....	9
14.3 Functional test	9
15 Fault reaction and restart condition	9
16 User interface	10
16.1 Scrolling help texts in display line 3.....	10
16.2 Routing diagram.....	11
16.3 Routing diagram - Advanced settings (ADV.SET).....	12
17. Connections diagram	13

1. Observed standards

Standard	Description
IEC 61508	Functional Safety of electrical / electronic / programmable electronic safety-related systems
IEC 61508-2:2000	Part 2: Requirements for electrical / electronic / programmable electronic safety-related systems
IEC 61508-3:1998	Part 3: Software requirements
IEC 61326-3-1:2008	Immunity requirements for safety-related systems

2. Acronyms and abbreviations

Acronym / Abbreviation	Designation	Description
Element		Term defined by IEC 61508 as “part of a subsystem comprising a single component or any group of components that performs one or more element safety functions”
PFD	Probability of Failure on Demand	This is the likelihood of dangerous safety function failures occurring on demand.
PFH	Probability of dangerous Failure per Hour	The term “Probability” is misleading, as IEC 61508 defines a Rate.
SFF	Safe Failure Fraction	Safe Failure Fraction summarises the fraction of failures which lead to a safe state and the fraction of failures which will be detected by diagnostic measures and lead to a defined safety action.
SIF	Safety Integrity Function	Function that provides fault detection (to ensure the necessary safety integrity for the safety functions)
SIL	Safety Integrity Level	The international standard IEC 61508 specifies four discrete safety integrity levels (SIL 1 to SIL 4). Each level corresponds to a specific probability range regarding the failure of a safety function.

3. Purpose of the product

Pulse isolator for transmission of signals to the safe area from NAMUR sensors and mechanical switches installed in the hazardous area.

The module can be mounted in the safe area and in zone 2 / div. 2 and receive signals from zone 0, 1, 2, 20, 21 and 22 / Class I/II/III, Div. 1, Gr. A-G.

Error events, including cable breakage, are monitored and signalled via the individual status relay and/or a collective electronic signal via the power rail.

The 9202 has been designed, developed and certified for use in SIL 2 applications according to the requirements of IEC 61508.

4. Assumptions and restrictions for use of the product

4.1 Basic safety specifications

Operational temperature range -20...+60°C

Storage temperature range -20...+85°C

Power supply type, min. Double or reinforced

Supply voltage 19.2...31.2 VDC

Output pulse length, min. 40 µs

Mounting area Zone 2 / Division 2 or safe area

Mounting environment Pollution degree 2 or better

4.2 Associated equipment

4.2.1 Relay output

The relay output shall only be connected to equipment which has a current limiting function of 2 A.

4.2.2 Opto output

The opto output signals are fed to SIL 2 compliant inputs of a safety PLC specified to receive a frequency of 5 kHz and a pulse length down to 40 microseconds or the field device signal pulse length minus 60 microseconds.

4.2.3 Field device

The field device must provide a minimum pulse length of 100 microseconds.

4.3 Failure rates

The basic failure rates from the Siemens standard SN 29500 are used as the failure rate database.

Failure rates are constant, wear-out mechanisms are not included.

External power supply failure rates are not included.

4.4 Safe parameterisation

The user is responsible for verifying the correctness of the configuration parameters. (See section 14 Safe parameterisation - user responsibility).

Manual override may not be used for safety applications.

4.5 Installation in hazardous areas

The IECex Installation drawing, ATEX Installation drawing and FM Installation drawing shall be followed if the products are installed in hazardous areas.

5. Functional specification of the safety functions

Pulse isolator as well as supply of NAMUR sensors and mechanical switches with cable error detection installed in the hazardous area. Cable error detection only works with NAMUR sensors or with the use of external resistors R_S and R_P . See connections diagram at page 13 (switch, cable fault) .

6. Functional specification of the non-safety functions

The status relay (terminal 33 and 34), error signal on power rail (terminal 91) and LED outputs are not suitable for use in any Safety Instrumented Function.

7. Safety parameters

	Relay	Opto
Probability of dangerous Failure per Hour (PFH)	4.66E-8	3.62E-8
	Note ¹ , Note ²	
Probability of failure on demand (PFD) - 1 year proof test interval	2.04E-4	1.58E-4
Proof test interval (10% of loop PFD)	4 years	5 years
Safe Failure Fraction	90%	91%
Demand response time, opto output	<125 μ s	
Demand response time, relay output	<10 ms	
Demand mode	High	
Demand rate	1000 s	
Mean Time To Repair (MTTR)	8 hours	
Diagnostic test interval	10 seconds	
Hardware Fault Tolerance (HFT)	0	
Component Type	B	
SIL capability	SIL 2	
Description of the "Safe State", opto output	High impedance	
Description of the "Safe State", relay output	De-energised	
Relay lifetime (Note ²)	100 000 times	

Note¹: The 9202 contains no lifetime limiting components, therefore the PFH figures are valid for up to 12 years, according to IEC 61508.

Note²: The maximum frequency for Pulse Isolator 9202 with relay output is 20 Hz. The user must calculate the product lifetime with regard to the relay lifetime.

8. Hardware and software configuration.

All configurations of software and hardware versions are fixed from factory, and cannot be changed by end-user or reseller.

This manual only covers products labelled with the product version (or range of versions) specified on the front page.

9. Failure category

Failure category	Failure rates (1/h)	
	Relay	Opto
Fail Safe Detected	0.000E+00	0.000E+00
Fail Safe Undetected	2.897E-07	2.755E-07
Fail Dangerous Detected	1.303E-07	1.356E-07
Fail Dangerous Undetected	4.658E-08	3.618E-08

10. Periodic proof test procedure

Step	Action
1	Bypass the safety PLC or take other appropriate action to avoid a false trip
2	Connect a simulator identical to the input setup
3	Perform an ON / OFF signal for each channel
4	Observe whether the output channel acts as expected
5	Restore the input terminals to full operation
6	Remove the bypass from the safety PLC or otherwise restore normal operation

This test will detect approximately 95% of possible “du” (dangerous undetected) failures in the pulse isolator. The proof test is equivalent to the functional test.

11. Procedures to repair or replace the product

Any failures that are detected and that compromise functional safety should be reported to the sales department at PR electronics A/S.

Repair of the module and replacement of circuit breakers must be done by PR electronics A/S only.

12. Maintenance

No maintenance required.

13. Documentation for routing diagram

The routing diagram is shown in section 16.2.

13.1 In general

When configuring the 9202, you will be guided through all parameters and you can choose the settings which fit the application. For each menu there is a scrolling help text which is automatically shown in line 3 on the display.

Configuration is carried out by use of the 3 function keys:

- ⬆ will increase the numerical value or choose the next parameter
- ⬇ will decrease the numerical value or choose the previous parameter
- Ⓞ will save the chosen value and proceed to the next menu

When configuration is completed, the display will return to the default state 1.0.

Pressing and holding Ⓞ will return to the previous menu or return to the default state (1.0) without saving the changed values or parameters.

If no key is activated for 1 minute, the display will return to the default state (1.0) without saving the changed values or parameters.

13.2 Further explanations

13.2.1 Password protection

Access to the configuration can be blocked by assigning a password. The password is saved in the module in order to ensure a high degree of protection against unauthorised modifications to the configuration. Default password 2008 allows access to all configuration menus.

Password protection is mandatory in SIL applications.

13.2.2 Cable fault information via display front 4501

Cable fault (see limits in the table) is displayed as CA.BR (cable break) or CA.SH (cable short-circuited). Cable fault is shown independently for each channel but the configuration is common for both channels. In case of cable fault the backlight flashes. This can be reset by pressing the Ⓞ key. When the cable fault has been remedied, the module will return to normal operation.

13.4 Advanced functions

The unit gives access to a number of advanced functions which can be reached by answering "Yes" to the point "adv.set".

13.4.1 Display setup

Here you can adjust the brightness contrast and the backlight. Setup of tag numbers with 5 alphanumerics. Selection of functional readout in line 2 and 3 of the display - choose between readout of digital output or tag no. When selecting "ALT" the readout toggles between digital output and tag no.

13.4.2 Password

Here you can choose a password between 0000 and 9999 in order to protect the unit against unauthorised modifications to the configuration. The unit is delivered default without password.

13.4.3 Language

In the menu "LANG" you can choose between 7 different language versions of help texts that will appear in the menu. You can choose between UK, DE, FR, IT, ES, SE and DK.

13.4.4 Power rail

In the menu "RAIL" you can choose if errors in the module are transmitted to the central surveillance in the PR 9410 power control unit.

13.4.5 Safety integrity level

See Safe parameterisation - user responsibility

14 Safe parameterisation - user responsibility

14.1 Safety-related configuration parameters

Parameters	Value	Description
CH1.FUN	DIR / INV	Direct / inverted channel function
CH2.FUN.	DIR / INV	Direct / inverted channel function
PASSW	0 - 9999	New password

The above safety-related configuration parameters are marked in red text in the routing diagrams and must be verified by the user in a SIL-configuration.

14.2 Verification procedure

The verification is done using the display / programming front PR 4501 by following the procedure described below.

14.2.1 If no password is set

	Action	Display shows
1	Press OK	ADV.SET
2	Set (ADV.SET) to Yes and press OK	DISP SETUP
3	Step down to (SIL SETUP) and press OK	EN.SIL
4	Set (EN SIL) to YES and press OK	NEW.PASS
5	Set password to a number between 0 and 9999 and press OK (At this time the module starts operating in SIL mode with the entered configuration parameters!)	Verify⇒OPEN "briefly" ⇒LOCK*
6	Verify Channel 1 function and press OK	CH1.FUN
7	Verify Channel 2 function and press OK	CH2:FUN
8	Verify password and press OK	PASSW
9	Verify SIL and press OK	

* Open is shown briefly in the display.

14.2.2 If password is set

	Action	Display shows
1	Press OK	PASSW
2	Enter password and press OK	ADV.SET
3	Set (ADV.SET) to Yes and press OK	DISP SETUP
4	Step down to (SIL SETUP) and press OK	EN.SIL
5	Set (EN SIL) to YES and press OK (At this time the module starts operating in SIL mode with the entered configuration parameters!)	Verify⇒OPEN "briefly" ⇒LOCK*
6	Verify Channel 1 function and press OK	CH1.FUN
7	Verify Channel 2 function and press OK	CH2:FUN
8	Verify password and press OK	PASSW
9	Verify SIL and press OK	

* Open is shown briefly in the display

14.3 Functional test

The user is responsible to make a functional test after verification of safety parameters. The procedure for periodic proof test described in section 10 shall be used.

15 Fault reaction and restart condition

When the 9202 detects a fault the output will go to Safe State, in which the opto output will go to "high impedance" or the relay output will go to "de-energised". If the fault is application-specific (cable error detection) the 9202 will restart when the fault has been corrected.

For device faults there are 2 ways of bringing the module out of Safe State.

1. Power cycle the module.
2. Bring the module out of SIL mode (choose "NO" in the menu point "EN.SIL"), and set it back to SIL mode again (choose "YES" in the menu point "EN.SIL" and verify the configuration).

16 User interface

16.1 Scrolling help texts in display line 3

- [01] Set correct password [PASS]
- [02] Enter advanced setup [ADV.SET]
- [03] Enable cable short circuit error indication [CA.SH]
- [04] Enable cable breakage error indication? [CA.BR]
- [05] Enable rail status signal output? [RAIL.ER]
- [06] Enter language setup [SETUP]
- [6/1] Enter password setup [SETUP]
- [6/2] Enter display setup [SETUP]
- [6/3] Enter rail setup [SETUP]
- [6/4] Enter SIL setup [SETUP]
- [07] Select direct channel function [CH1.FUN] [CH2.FUN]
Select inverted channel function [CH1.FUN] [CH2.FUN]
- [09] Adjust LCD contrast [CONTRA]
- [10] Adjust LCD backlight [LIGHT]
- [11] Write a 5-character channel ["TAGON] ["TAGON]
- [12] Show output state in display [DISP]
Show TAG in display
Alternate shown information in display
- [13] Configuration SIL status (Open / Locked) [CONFIG]
- [14] Enable SIL configuration lock [EN.SIL]
- [15] Enable password protection [EN.PASS]
- [16] Set new password [NEW.PAS]
- [17] Select language [LANGUA]
- [18] Cable short circuit [¹CA.SH] [²OFF]
- [19] Cable breakage [¹ON] [²CA.BR]

16.2 Routing diagram

If no key is activated for 1 minute, the display will return to the default state 1.0 without saving configuration changes.

⤴ Increase value / choose next parameter

⤵ Decrease value / choose previous parameter

⊗ Save the chosen value and proceed to the next menu

Hold ⊗ Back to previous menu / return to menu 1.0 without saving

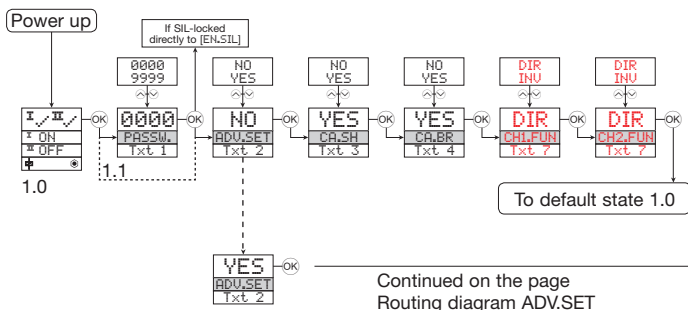

Continued on the page
Routing diagram ADV.SET

1.0 = Default state

Line 1 shows status for channel 1 and channel 2.

Line 2 shows status for sensor 1.

Line 3 shows status for sensor 2.

Line 4 indicates whether the module is SIL-locked.

1.1 = Only if password-protected

1.2 = If password has been set.

Line 1 symbols:

ⓘ✓ = OK. Flashing ⓘ! = error

Line 2 and 3 symbols:

Input frequency > 1 Hz = ⓘ □ □ □

Line 4 symbols:

Static dot = SIL-locked

Flashing dot = not SIL-locked

16.3 Routing diagram - Advanced settings (ADV.SET)

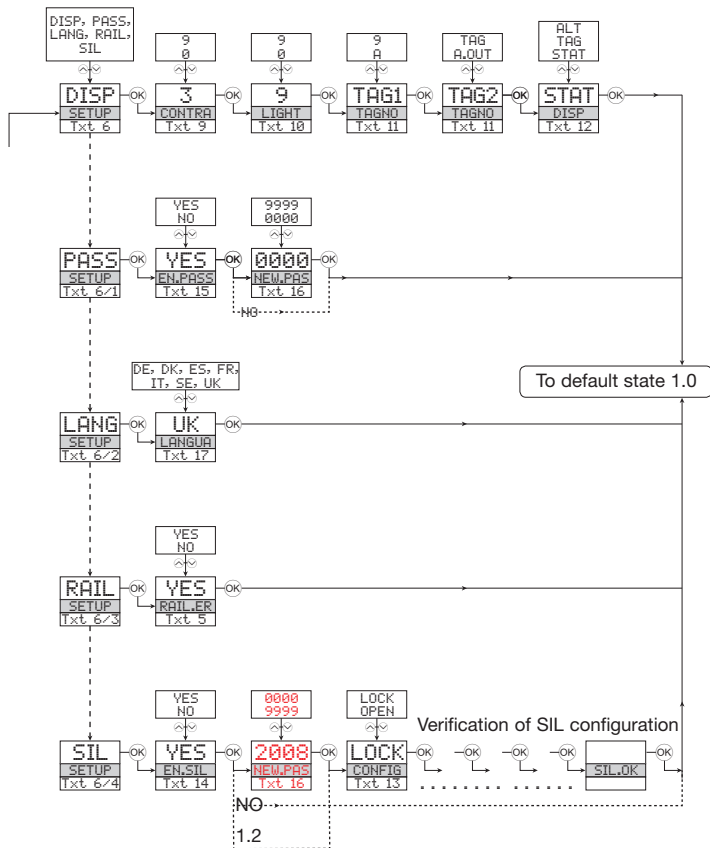

17. Connections diagram

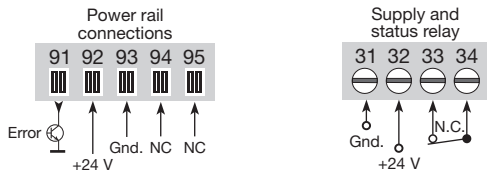

NC = no connection

Inputs:

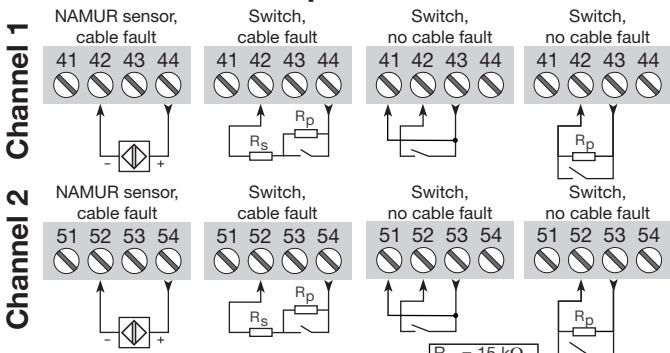

$R_p = 15\text{ k}\Omega$
 $R_s = 750\ \Omega$

Outputs:

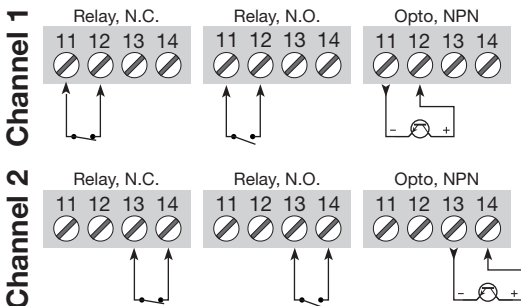



Displays Programmable displays with a wide selection of inputs and outputs for display of temperature, volume and weight, etc. Feature linearisation, scaling, and difference measurement functions for programming via PReset software.



Ex interfaces Interfaces for analogue and digital signals as well as HART® signals between sensors / I/P converters / frequency signals and control systems in Ex zone 0, 1 & 2 and for some modules in zone 20, 21 & 22.



Isolation Galvanic isolators for analogue and digital signals as well as HART® signals. A wide product range with both loop-powered and universal isolators featuring linearisation, inversion, and scaling of output signals.



Temperature A wide selection of transmitters for DIN form B mounting and DIN rail modules with analogue and digital bus communication ranging from application-specific to universal transmitters.



Universal PC or front programmable modules with universal options for input, output and supply. This range offers a number of advanced features such as process calibration, linearisation and auto-diagnosis.



- 
 www.preelectronics.fr
 sales@preelectronics.fr
- 
 www.preelectronics.de
 sales@preelectronics.de
- 
 www.preelectronics.es
 sales@preelectronics.es
- 
 www.preelectronics.it
 sales@preelectronics.it
- 
 www.preelectronics.se
 sales@preelectronics.se
- 
 www.preelectronics.co.uk
 sales@preelectronics.co.uk
- 
 www.preelectronics.com
 sales@preelectronics.com
- 
 www.preelectronics.cn
 sales@preelectronics.cn

Head office

Denmark
 PR electronics A/S
 Lerbakken 10
 DK-8410 Rønne

www.preelectronics.com
sales@preelectronics.dk
 tel. +45 86 37 26 77
 fax +45 86 37 30 85



QUALITY SYSTEM AND ENVIRONMENTAL
 MEDICAL MANAGEMENT SYSTEM
 DS/EN ISO 9001
 DS/EN ISO 14001

